

Receiver Protectors: Theory of Operation

CPI Electron Device Business

Introduction

This article will give the reader a basic understanding of receiver protector technology. It discusses the various available types of receiver protector forms, their strengths and weaknesses, and how best to use them. It should be stated at the outset that choosing the best receiver protector configuration for any given application normally involves analyzing the needs of many conflicting operating requirements. Very often, apparent nuances in performance requirements can have a large effect on the final design approach. For those reasons, it is always advisable for the prospective user to consult with CPI EDB's technical experts as early as possible in the design phase of a new application.

Receiver protectors are used in radar systems to protect the radar receiver from unwanted and potentially damaging high power signals. These signals may be the reflected remnants of its own radar transmitter output or they may enter the system from outside sources. In any case, these signals are usually on the order of kilowatts to megawatts of peak power -- far too much for any receiver to survive.

In some configurations, the receiver protector may be a singular component which is located in the receive channel, just before the receiver. In other configurations, the receiver protector may also do "double duty" and actually perform the function of the radar duplexer as well. For that reason, this article will begin with a discussion of common duplexing techniques.

Radar Duplexers

Most radar systems (including missile seekers) use one antenna to perform the transmit and receive functions. Since most radars utilize very high power transmitters and very sensitive receivers, a radar using only one antenna requires a "front end" configuration which will alternately "connect" and "disconnect" the transmitter and receiver from the antenna on a pulse to pulse basis.

This is the function of the duplexer. A duplexer, in effect, acts as a very fast, self-actuating SPDT or transmit - receive switch.

The duplexer must be able to perform the following main functions:

- Connect the transmitter to the antenna (and disconnect the receiver) during the sending period.
- Connect the receiver to the antenna (and disconnect the transmitter) during the receive period.
- Provide for adequate isolation between the receiver and transmitter at all times.

There are three main types of radar duplexers in common use. Each is discussed below.

Branched Duplexers

A typical branched duplexer is shown in Figure 1. This type of duplexer came into use during World War II and is still in use today in low cost radars, such as those found on small boats. The branched duplexer may employ one or more ATR (Anti-Transmit-Receive Tubes) and a receiver protector (RP).

During the transmit period, both the ATR and RP activate and present very low impedances at the waveguide walls which allows the transmitted energy to pass through to the antenna with low attenuation. Also, the RP provides additional receiver protection against that portion of the transmit pulse that leaks into the receive channel.

During the receive period, the receive signal passes through the inactivated RP (which is well matched to the transmission line impedance in this state) to the receiver. The ATR is also inactivated at this time. Its position is such that a high impedance is presented to the receive signal in the direction of the transmit channel, thus minimizing the loss of return signal energy in that direction.

CPI Electron Device Business

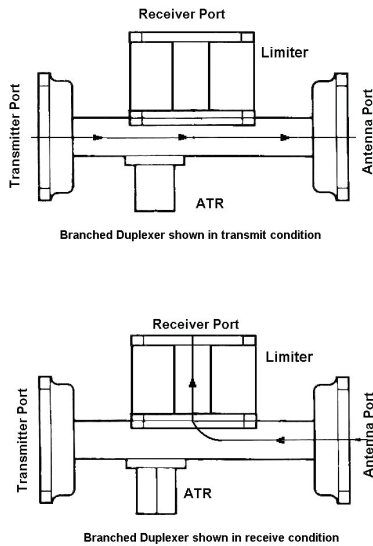

FIGURE 1

The main advantages to the branched duplexer are that it is simple, compact, and low cost. The main disadvantage is that it has a relatively limited operating bandwidth (approximately 5%) due to the fact that element spacings are critical.

Balanced Duplexers

Balanced duplexers make use of the features of two 3 dB short slot hybrid couplers, in combination with a switching element, to control the direction of power flow (Figure 2). A dual channel switching element is placed between two hybrids. The “switching element” could be any one of a number of receiver protector types (Pre-TR tube, TR tube, TRL, etc.) depending on the required performance parameters.

During the transmit period, the high power energy will enter at the transmit port and be split in half in each of the two channels. The switching element will activate presenting very low impedance at the dual channel plane of the input hybrid. The phase characteristics of the hybrid are such that the high power energy reflected at this plane will recombine in the antenna port, thus enabling the high power pulse to

be directed from the transmitter out to the antenna with low loss. Because the switching element is, itself, a receiver protector, it will provide some amount of receiver protection against energy that would otherwise attempt to pass through to the receiver. Additional protection would be provided by the isolation characteristic of the output hybrid. If, due to the nature of the configuration, more receiver protection is required, a separate receiver protector component could be used in the receive channel just ahead of the receiver.

During the receive period, the receive signal enters at the antenna port, splits in the hybrid and passes through the switching element, which is inactive. This signal then passes through the output hybrid and, due to its phase characteristics, recombines in the receive channel.

Balanced duplexers may be designed in many different configurations, depending upon system requirements. For example, the dual switching element could be an entire TR Limiter. In this case, the switching element would also perform the full receiver protector function. An alternative approach might be to use only a Pre-TR tube as the switching element. In this case, a receiver protector would likely be required in the receive channel. It is also possible to employ ATR tubes as the switching element in a balanced duplexer. The choice of configuration depends on system requirements. CPI EDB’s Engineering Department should be consulted to determine the optimum configuration for your system.

The balanced duplexer provides advantages in the areas of power handling capability and operating bandwidth. The main disadvantage is physical size and, potentially, relative port locations. To some extent, this can be ameliorated by clever physical layout.

CPI Electron Device Business

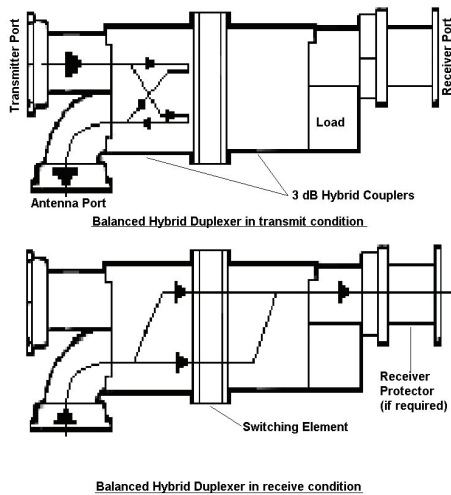
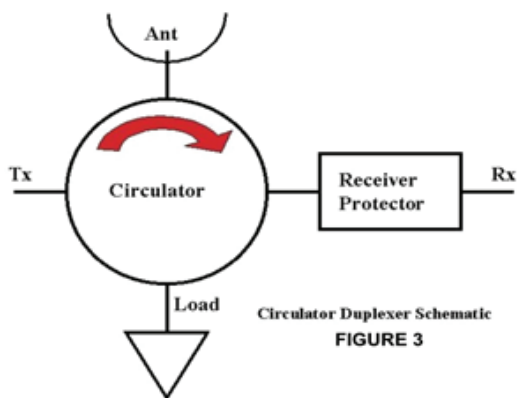

Figure 2

Ferrite Circulators

The ferrite circulator is, perhaps, the most common component employed to perform the duplexing function in most new system configurations. As its name implies, this component's ability to circulate power from port to port allows it to be employed as a duplexer, as shown in Figure 3. Strictly speaking, a duplexer is a three port device. And, therefore, it is theoretically possible to use a single junction, 3-port circulator as a duplexer. However, in most systems, this is not practical due to the fact that, in that case, much of the transmitter power would be reflected back into the transmitter, itself. Therefore, most duplexers are configured with 4-port circulators. This



may be done either by using two 3-port circulators or by using a differential phase shift circulator, which is an inherently four port device. Differential circulators are capable of much higher power handling than junction circulators. So, in practice, most duplexers are of this type.

In any case, the use of a ferrite circulator as duplexer will almost certainly require the use of a receiver protector in the receive channel. This is true because, depending upon bandwidth and design, the circulator will normally provide only 10 to 20 dB of isolation between the transmitter and receiver. This low amount of isolation is acceptable for only a small number of very low power systems. Therefore, a separate receiver protector is normally required.

Like balanced duplexers, ferrite circulators are relatively broadband components and they tend to be more compact (although this may not always be the case). Although there are exceptions, for most systems, ferrite circulators seem to provide the best balance between physical size, cost, and operating characteristics.

Receiver Protector Technical Terms and Considerations

Before delving into the discussion of the various types of receiver protectors and how they function, it is necessary to have a clear understanding of some technical terms as they relate to this particular product class.

Unlike most microwave components, receiver protectors must function successfully in three completely different operating states. The first two are usually called low power and high power states. In the low power state, the receiver protector is, effectively, inactivated. In this state, the desire is that the component be well matched to the transmission line so that the returning echo signal can pass through to the receiver with as low an insertion loss as possible. In the high power state, the device activates to protect the receiver from unwanted and potentially damaging high power signals. In the third state, the unit is in transition as it reverts back from the high power state to the low power state. This third state is normally referred to as recovery time.

CPI Electron Device Business

In terms of receiver protector design considerations, the needs of these three states often conflict with one another, thus requiring many tradeoffs in design to achieve overall optimum performance. The next sections will discuss terms and considerations that are important for receiver protector characterization and design.

Low Power State

The low power state is sometimes referred to as the insertion loss state. This is the state that the receiver protector is in during the period of time that the radar system is quiescent and “listening” for target return echoes. In this state, the protector must be as well matched as possible and provide minimum insertion loss. To the system designer, the receiver protector’s insertion loss means a dB for dB increase in noise figure. Therefore, in this state, design consideration is focused on achieving the desired instantaneous bandwidth with low VSWR and low absorptive losses. In some cases, such as for monopulse systems, the unit’s insertion phase characteristic and/or its ability to phase track other units is also important.

One important consideration for receiver protector design in this state is the maximum input power level that the receive signal is expected to have. Receiver protector designs are done with the expectation that this level will not exceed -10 dBm (0.1 mW) peak. Above this power level, the standard receiver protector may be expected to begin to limit, thus compressing the input signal and/or causing unwanted signals such as harmonics or intermod products. For most systems, operation below -10 dBm is more than adequate. However, depending upon other performance tradeoffs, it is often possible to design receiver protectors to hold off compression to higher power levels (such as 0 dBm or +10 dBm) when the need requires.

High Power State

The high power state refers to the unit’s condition when it is activated and protecting the receiver from high power signals.

Inputs

The first step in high power design is to gain a complete understanding of the nature of all high power signals that could, potentially, be incident in the receive channel. These signals can come from a number of sources in a number of different ways:

- The system’s own transmitter under normal operating conditions – This is the amount of power (referred to as “Normal Operating Power”) that may be expected to be incident on the receiver protector when the system is operating normally. This is not the full transmitter power. Rather, it is a combination of the transmitter power that leaks through the duplexer to the receive channel plus the amount of power that is reflected into the receive channel as a result of the VSWR mismatch in the antenna channel (See Figure 4). In most systems the component reflected from the antenna port is far greater than that which leaks through the duplexer. If it is not otherwise known or specified the receiver protector will be designed with the idea that the Normal Operating Power is 10 dB below the transmitter power.
- Overload Power – This is the amount of power that would be incident in the receive channel in the event of an arc or catastrophic failure elsewhere in the system. In order to be safe, unless otherwise known, the Overload Power is assumed to be the full transmitter power.

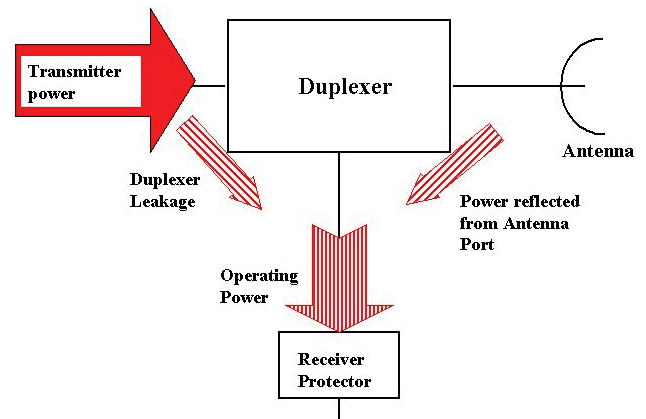

FIGURE 4

CPI Electron Device Business

- In – band signals that enter the system through the antenna as a result of the emanations of other, nearby systems.
- Out of band signals – Again, these can be the received emanations of outside, nearby systems or they can be present as a result of transients, harmonics, and other out of band signals present on the system's own transmitter signal. This should be investigated very closely by the system designer. It has been the case in the past that such signals, which can be very difficult to detect, may cause the most problems. There are cases on record in which, after the fact, the receiver protectors in some radar systems have had to be replaced by upgraded designs because these out of band signals were not identified during the initial design process and were belatedly discovered to cause system operating problems.

Identification and characterization of all high power signals must be done in terms of their frequencies, peak power, pulsewidth, and duty cycle. Many modern systems operate with widely varying pulse and duty conditions. The receiver protector design engineer needs to know as much about these as possible. As a minimum, knowledge and specification of the maximum power levels and minimum and maximum pulsewidths and duty cycles are required.

Another important aspect of the input power characteristic is the pulse risetime. It takes a finite amount of time for any receiver protector to transition into its high power state. During this transition time, the leakage pulse will be somewhat higher than during the remaining portion of the pulse, when the unit has achieved its maximum protection characteristic. This transition period is referred to as the "spike." Its amplitude and width will depend, to some extent, on the risetime of the input pulse. In general, the spike amplitude will be higher for faster risetime.

Outputs

The output during the high power state is the form and the amount of energy that leaks through the unit

as it performs its protection function. The performance characteristics that are relevant in this state are the Breakdown Power, Spike Leakage Power and Energy, and the Flat Power. With the exception of the Spike Energy, these parameters are amplitude parameters which are measured on the leakage pulse. Spike energy is a calculation which is based on the amplitude and width of the spike component of the leakage pulse.

Breakdown Power is, perhaps the most misunderstood of the leakage parameters. It can best be explained in the following way. In the Low Power State, a receiver protector is inactive. Therefore, at low power levels, the output pulse will approximately equal the amplitude and form of the input pulse. As the amplitude of the input pulse increases, the output pulse will, likewise, increase. At some point, depending upon the type of receiver protector, the unit will begin to activate and transition into its protection mode. This transition could be very abrupt (as in the case of a TR tube) or very gradual (as in the case of a diode limiter). In any case, there will come a point where the amplitude of the leakage pulse begins to decline for further increases of the input amplitude. This is the Breakdown Point. The Breakdown Power is, by definition and industry convention, the amplitude of the leakage pulse at the point where further increases of the input power result in a decline in the leakage power. Therefore, in general, the Breakdown Power is the maximum full pulse leakage power that will be transmitted by the receiver protector for any value of input power within its rated operating power range. For input power levels beyond the Breakdown Point, the leakage pulse will take the form of a spike and flat. As described in the section above, the spike is that portion of the leakage pulse which is at the leading edge and is the result of the finite amount of time it takes for the receiver protector to go into hard limiting. The flat is the main portion of the leakage pulse, which is exhibited after maximum limiting has been realized. Figure 5 shows these relationships in a general way.

CPI Electron Device Business

Depending upon the type of receiver protector, pulse risetime, etc., the spike width will typically range between 2 and 20 nanoseconds. Spike energy is calculated as the area under the spike power - time curve. In practice, the convention is to treat the spike as a triangle and measure its width 3 dB below the peak amplitude. The spike energy is then calculated as:

Spike Energy = (Spike Power - Specified Flat Power) multiplied by the spike width

This may be expressed either in ergs or nanojoules. In the past, spike energy was an important leakage parameter. However, for most modern systems, the spike amplitude requirement is so low that, in most cases, the energy is a non-issue as far as receiver protection is concerned. Very often, there is no point in even specifying it.

Clearly, a complete and accurate understanding of the power range over which the receiver protector will be expected to operate is very important for proper design and specification. If the unit is always expected to operate well above its breakdown point, then the Breakdown Power parameter may be of no practical concern. However, if the normal operating point of the receiver protector will be at, or close to, the breakdown point, then the Breakdown Power may be the most important leakage parameter.

Recovery Time

In the Recovery Time state, the unit is in the process of transitioning back to the Low Power state from the High Power state. Recovery time measurement begins at the cessation of the transmitter pulse. This means the point on the trailing edge of the transmitter pulse where the power has dropped below the level at which limiting would be expected to occur. For all practical purposes, this means that the recovery time measurement begins at the point in time at which the input power has dropped to zero. See Figure 6.

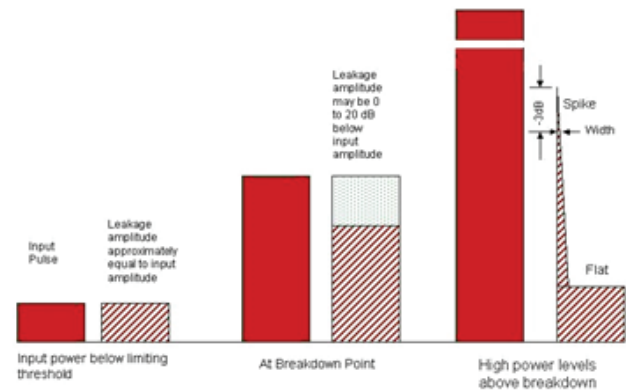

Input - Output Characteristic Waveforms
FIGURE 5

The end point of the recovery time measurement may vary from product to product and is often based on the requirements of the system application. However, lacking any other specification, the standard industry definition is that recovery time is measured from the cessation of the transmitter pulse to the point at which the unit has returned to within -3dB of its quiescent insertion loss value.

The following key points regarding recovery time are relevant:

- Recovery time is a relative measurement. The end point of the measurement is made relative to the quiescent insertion loss value. For example, if the insertion loss of a particular unit is 0.5 dB, and the recovery measurement is specified to the 3 dB point, then the absolute insertion loss at the point of measurement will be 3.5 dB.
- Although amplitude recovery is, by far, the most common parameter specified, it is also possible to specify phase recovery when required.
- The need to meet a certain value of recovery time is fundamental in terms of choosing the best design approach for a particular application. Designing for a very fast recovery time can adversely affect other parameters. Therefore, it is very important to specify the recovery time as carefully as possible.

CPI Electron Device Business

- As is discussed below, the various receiver protector technologies exhibit widely different recovery characteristics. In general, however, the recovery time for any given unit is a function of the incident power and pulsewidth. Higher power and wider pulsewidths mean longer recovery times.
- Although a receiver protector should be designed to successfully handle and protect against all power levels up to its rated overload power, recovery time is usually specified only up to the maximum Normal Operating Power
- Clearly, from the discussion above, it can be seen that control of the trailing edge of the transmitter pulse is critical for fast recovery time requirements. A slow trailing edge can significantly delay the start of the recovery process.

One final point: Although recovery time is a function of input power, this must be looked at on an element by element basis within the receiver protector. Each element within the receiver protector may have a different recovery characteristic and some elements may be protected by other elements. Therefore, the interaction between each of the elements in a receiver protector, as it relates to recovery time, is complex. For the end user, this may mean that, in some designs, the power level at which maximum recovery is observed may not be the maximum Normal Operating Power. In fact, in some designs, the maximum recovery time will be at power levels well below that point. This is another reason why a complete understanding of the expected operating power input characteristic is so important in order to optimize receiver protector performance.

Receiver Protector Design and Operation

This section will give a brief overview of the basic receiver protector technologies. It will begin with a

discussion of active and passive receiver protectors, followed by a discussion of the various technologies used in receiver protector design and their operating characteristics.

Active vs. Passive

Simply stated, a passive receiver protector is one which is self-activated and requires no external control to perform its protection function. An active receiver protector is, basically, a switch. Typically, SPST's or SPDT's are used to realize this type of design.

There are also hybrid designs, called "quasi-active", which employ a combination of passive and active elements.

All other things being equal, the passive approach is, by far, the preferred approach for any application. It will give more reliable protection over a much wider range of potential threats than is possible with an active protector. It is totally automatic and self-activating. It will perform its protection function against external signals (any for which it is designed) even if the radar is turned off.

Typically, the main reasons for using an active receiver protector are that, in some cases, it may be possible to achieve an all solid state design, faster recovery time, or in the case of an extremely low leakage requirement (less than +10 dBm).

However, normally, these benefits are more than adversely offset by the following risks, which are inherent in active receiver protector design:

- If the control signal fails, the receiver protector will fail. This is an additional factor which will reduce the inherent reliability of this approach.
- Active receiver protectors can only protect against signals which are synchronized with the transmitter pulse. Thus, there will be no protection for non-synchronous, external signals.

CPI Electron Device Business

protector is, basically, a switch. Typically, SPST's or SPDT's are used to realize this type of design.

There are also hybrid designs, called "quasi-active", which employ a combination of passive and active elements.

All other things being equal, the passive approach is, by far, the preferred approach for any application. It will give more reliable protection over a much wider range of potential threats than is possible with an active protector. It is totally automatic and self-activating. It will perform its protection function against external signals (any for which it is designed) even if the radar is turned off.

Typically, the main reasons for using an active receiver protector are that, in some cases, it may be possible to achieve an all solid state design, faster recovery time, or in the case of an extremely low leakage requirement (less than +10 dBm).

However, normally, these benefits are more than adversely offset by the following risks, which are inherent in active receiver protector design:

- If the control signal fails, the receiver protector will fail. This is an additional factor which will reduce the inherent reliability of this approach.
- Active receiver protectors can only protect against signals which are synchronized with the transmitter pulse. Thus, there will be no protection for non-synchronous, external signals.

No protection is provided if the system is turned off. In some cases, it may be possible to design a receiver protector which, while providing basic receiver protection passively, may incorporate an active capability to enhance performance under normal operating conditions. This is also a reasonable alternative. However, active or quasi-active receiver protectors which require external control to perform the basic protection function are not recommended unless there is no other way to achieve desired overall performance and there is low or, preferably, no possibility of threats that may take advantage of the weaknesses inherent in this design approach.

Basic Receiver Protector Technologies

The best way to understand receiver protector technology is to realize that a receiver protector is usually not a singular component. In fact, it is normally an assembly of two or more elements, each of which employs different basic technologies. There are five basic technologies in common use today: TR tube, Pre-TR tube, ferrite limiter, diode limiter, and multipactor. Each technology has its own set of strengths and weaknesses. For any given design, the challenge for the engineer is to employ that combination of technologies which gives the best overall performance in light of the applicable requirements for that application. A discussion of each of the five technologies follows.

TR Tube

The TR tube is the most common receiver protector technology in use today. The construction of the TR tube includes one or more resonant filter sections in a piece of waveguide which is sealed at both ends with waveguide windows. Each filter section is a relatively high Q parallel L-C circuit. Truncated cones form the capacitive element and irises or posts the inductive element. These can be seen in Figure 7. The waveguide is then evacuated and back-filled with a gas, or combination of gasses, at below atmospheric pressure.

In the low power state, the TR tube is a bandpass filter whose characteristics are controlled by the dimensions and spacing of the filter elements and the windows. These dimensions are adjusted so as to realize minimum VSWR and insertion loss over the band of interest. The presence of a high power signal will cause an arc between the cone gaps. This will ionize the gas in the region of the cones, thus causing most of the power to be reflected from the device. If the power is high enough, the input window will fire as well, providing additional protection.

Gas discharges are inherently unstable. For that reason, some means of "priming" the gas is necessary in order to ensure stable firing on each and every pulse. The earliest TR tube designs employed

CPI Electron Device Business

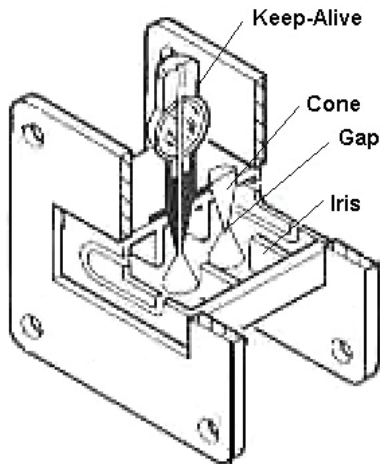

**TR Tube with Keep-Alive
FIGURE 7**

every pulse. The earliest TR tube designs employed a small electrode, called a “keep-alive”, for this purpose. This is shown in Figure 7. The keep-alive was placed down the middle of one of the cones, which had been hollowed out for this purpose. The application of approximately -1000 VDC on the keep-alive would result in a constant trickle current between the electrode and the cone surface, thus providing free electrons for gas priming. This arrangement works well. However, in addition to the inconvenience of requiring a power supply, the keep-alive also limits useful tube life and is a source of a small amount of excess noise.

In order to overcome these problems, radioactive priming was developed. This method employs a very small radioactive source, which is enclosed within the TR tube body. The radioactive source is positioned so as to illuminate one of the cone gaps, thus providing a source of electrons for stable firing. Virtually all modern TR tubes use radioactive priming. It is a very safe technique which eliminates the need for the large power supply, makes the unit totally passive, and greatly increases tube life. It also eliminates the excess noise that the keep-alive had introduced. Please see the CPI EDB website (www.cpi-edb.com) for additional information.

The salient characteristics of the TR tube are as follows:

- It provides a great deal of protection at a relatively low cost. For many applications it is unquestionably the best value.
- In addition to its performance within its fundamental operating frequency range, the TR tube also will provide a great deal of protection at out of band frequencies. This additional protection is realized as an inherent characteristic of the technology and comes at no extra cost.
- It is a moderate power handling device. Power handling is primarily limited by the temperature rise on the glass input window due to the gas discharge. This can be increased significantly by employing a ceramic window where necessary.
- The TR tube has a relatively long recovery time. Recovery time is directly related to input power and pulsewidth and inversely related to operating frequency.
- The TR tube has a limited operating life. Life is a function of the gas volume as well as other parameters such as power and duty cycle. A gas reservoir may be employed to extend operating life. For additional information, please see the CPI EDB website (www.cpi-edb.com).
- The TR tube has a very great dynamic operating power range and is very forgiving should its power handling rating be exceeded. The nature of the technology is such that its attenuation increases with increasing power. Thus, once activated, its flat leakage power remains quite constant for increasing input power levels.

Pre-TR Tube

The Pre-TR tube is also a gas plasma limiter and operates on the same principle as the TR tube

CPI Electron Device Business

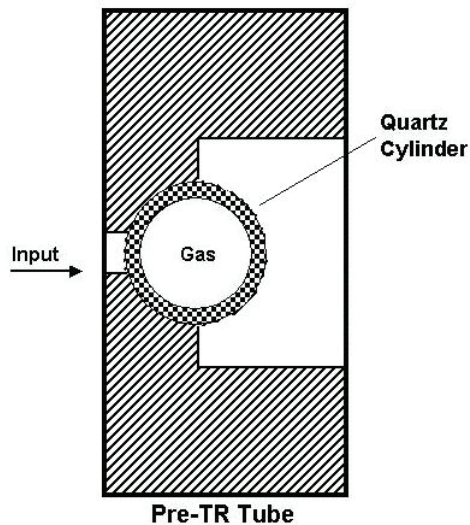

FIGURE 8

described above. The difference is that, in the Pre-TR tube, the gas is enclosed in a quartz tube (See Figure 8). This provides two advantages:

- Quartz has a much higher melting point than glass. Thus, a Pre-TR tube will handle much more power than a TR tube.
- Enclosing the gas entirely within a quartz cylinder allows for the use of gasses that cannot be used in a body-filled TR tube. These gasses have much faster recovery times.

Also, this technology exhibits very low insertion loss (typically less than 0.1 dB).

The main disadvantage to the Pre-TR is that its low Q circuit will not provide as much protection, either in-band or out of band, as does the TR tube. Thus, the Pre-TR is employed as a low loss "pre-limiting" device at the input of a receiver protector assembly which allows the overall assembly to handle virtually any amount of power. The pre-TR must be followed by other receiver protector devices (Diode Limiter or TR Limiter) which will "clean up" the leakage to levels which are safe for the receiver.

Ferrite Limiter

The ferrite limiter is an all solid state product. It employs ferrite material which is mounted along one or both waveguide walls (See Figure 9). The ferrite is magnetically biased with permanent magnets. The electrons in the ferrite will precess around the magnetic field lines. In the low power state, this device looks like a dielectrically loaded piece of waveguide. However, when the input power reaches a critical threshold, the RF energy will couple into the precession motion causing the ferrite to absorb power as the RF passes down the waveguide. The absorbed energy is converted to heat.

A ferrite limiter is a medium power handling device, suitable for use in applications where the average power is relatively low. Its main advantages are:

Its main disadvantages are that it exhibits relatively high insertion loss, can handle only a moderate amount of power and its performance is very sensitive to changes in ambient temperature. Also, its leakage is too high for a receiver to sustain. Thus, a ferrite limiter may be employed as a pre-limiting device in a receiver protector assembly where very fast recovery time is required. It is normally followed by a diode limiter.

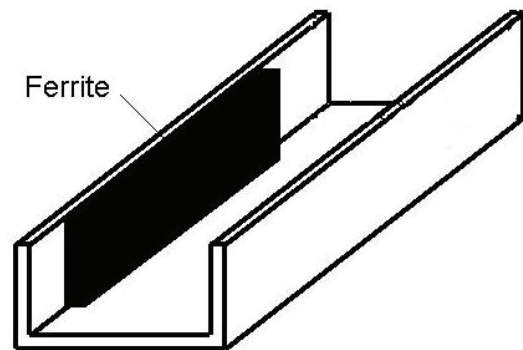

Ferrite Limiter
(Cutaway View)

FIGURE 9

CPI Electron Device Business

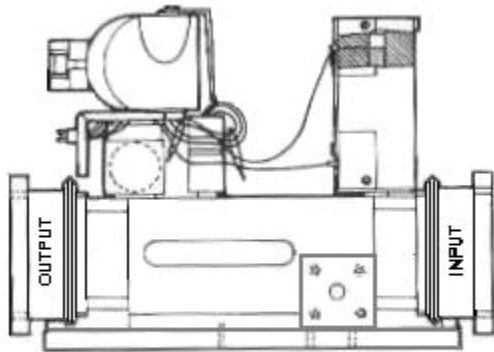

Multipactor
FIGURE 10

Multipactor

The multipactor is a vacuum device which employs secondary emission materials to absorb large amounts of RF power (See Figure 10). It is designed to be a band-pass filter in the low power state. When the input RF power reaches a critical threshold, multipaction, enhanced by the presence of secondary emission material, takes place. This causes power to be absorbed as the RF energy passes down the waveguide. The absorbed energy is converted to heat. Although its limiting action is passive, the multipactor does require a number of DC supplies to operate certain of its key components. In addition, it must be liquid cooled.

The main advantages to the multipactor are that it handles a large amount of average power and has virtually instantaneous recovery time (typically less than 10 nanoseconds). It is a limited life product and, as mentioned above, does require external DC bias. Like the other technologies discussed above, it must be followed by a diode limiter to clean up the leakage to levels which are safe for the receiver.

Diode Limiter

Since its inception in the late 1960's, the diode limiter has become fundamental building block of virtually every modern receiver protector design. To a large extent, this is because, other than an active (keep-alive primed) TR tube, it is the only receiver protector form that is capable of adequately protect

ing a modern receiver. All of the other devices described above are pre-limiting devices that must be followed by a diode limiter to achieve adequate protection.

The diode limiter's advantages are many:

- It is an all solid state product which has no operating life limit
- It does not require priming of any kind.
- It may be passive or active
- It may be designed as a multifunction component so that the benefits of additional functionality
- May be realized with a minimum size and insertion loss.
- May be realized in any type of transmission line

The main factor which restricts a diode limiter's usefulness is its power handling capability. In the early days, these devices were capable of handling only a few tens of watts of peak power. However, over the years, great strides have been made. Today, diode limiters are being designed as stand-alone receiver protectors into applications that once would have required the additional use of other pre-limiting technologies. Diode limiter power handling is, primarily, a function of operating frequency, peak power, and pulsewidth.

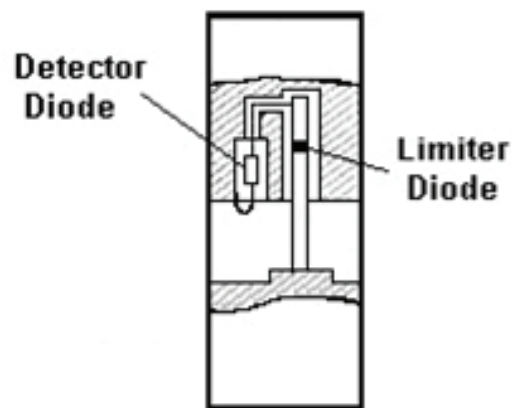

Diode Limiter
FIGURE 11

CPI Electron Device Business

A typical single stage waveguide diode limiter is shown in Figure 11. The diode is mounted in a tunable choke section. In the low power state, the diode is not conducting. The choke section is tuned so as to provide the desired bandpass characteristic insertion loss and VSWR. In the high power state, the RF causes the diode to conduct. This detunes the circuit, thus causing a high reflection.

To complete the "DC" circuit, the diode, itself may be returned directly to ground or through a detector diode. Detector diodes may be used to provide a better current source for high power handling or to reduce leakage. depending upon bandwidth, a single diode stage may be expected to provide 15 - 20 dB of protection. Additional stages may be cascaded as necessary to achieve the desired amount of attenuation. Of course, insertion loss will increase as each stage is added.

The onset of limiting will occur at relatively low power levels, typically 0 to +10dBm. Thus, the leakage power will be low enough to adequately protect a modern receiver. Additionally, the diode limiter may be actively controlled to achieve greater power handling or lower leakage.

There are two main disadvantages with diode limiters. First, unlike the other technologies discussed above, they are not very forgiving. If subjected to even a slightly higher power level than their design rating, they may be degraded or destroyed. Second, they generally do not provide much out of band protection. Therefore, in order to avoid problems when considering the use of a diode limiter as a stand-alone receiver protector, it is incumbent upon the user to very carefully profile all of the expected in-band and out-of-band energy that may be incident upon the limiter.

The Receiver Protector Assembly

As noted above, most receiver protectors are not stand-alone components. They are actually assemblies which utilize two or more of the basic building block technologies discussed above.

Most receiver protectors will employ a diode limiter, as the basic element, to achieve the desired protection levels. Beyond that, depending upon the specific system requirements, one or more of the pre-limiting technologies may be employed. This is typically done either to achieve the desired overall power handling capability or recovery time.

Typical combinations are:

- TR Limiter -- Combination of TR tube and Diode Limiter
- Pre-TR, Limiter -- Combination of Pre-TR tube and Diode Limiter
- Pre-TR, TR Limiter -- Combination of Pre-TR tube, TR Tube, and Diode Limiter.
- Ferrite-Diode Limiter -- Combination of Ferrite Limiter and Diode Limiter

The many tradeoffs which must be considered when designing a receiver protector are too complex to describe in a brief article. Each application involves a different set of design criteria. Therefore, each application requires its own special receiver protector design. CPI EDB's engineering staff should be consulted during the design phase of any new system or upgrade.

One final note. Although comprised of individual building blocks, the receiver protector assembly should always be treated as a singular component. In other words, the building blocks should never be separated physically in the system design. The receiver protectors with the best performance are, invariably, those in which the various building blocks are made to work together. Electrical spacing between elements is critical. And, some tuning is a normal part of receiver protector manufacture. The component parts should, in general, not be separated.

How to Specify a Receiver Protector

The following page contains a blank specification sheet which may be used to describe a new receiver protector requirement. We have tried to make the specification sheet as inclusive as possible. However, there may be other subtle issues which relate to a

CPI Electron Device Business

particular system application. Some of the information requested (such as phase tracking or STC) may not apply to a particular application. However, there is a minimum amount of information that is required for any application. These items are noted by an asterisk (*) on the specification sheet.

In general, and in order to be able to choose the best design configuration possible, the receiver protector design engineer should be given as complete an understanding as possible about the prospective environment in which the device will be expected to operate. This should be done as early as possible in the design phase of any new system.

CPI Electron Device Business

Receiver Protector Description

	MIN	MAX	UNITS
Electrical			
• Frequency			
• Peak Power (Overload)			
• Peak Power (Normal Operating)			
• Pulsewidth(s)			
• PRF(s)			
• Leakage Power:			
Spike			
Flat			
• Recovery Time			
• Insertion Loss			
• VSWR			
• Phase Matching (if required)			

Multifunction Capability (if desired)

Variable or Programmed Attenuation -- Specify amount, type, control method, available bias supplies, etc.

Excess Noise Generator -- Specify amount, control method, etc.

Mechanical

Overall Size

Connectors

Transmission Line

Environmental

Internal Waveguide Pressure

Operating Temperature

Altitude

With a history of producing high quality products, we can help you with your receiver protectors. Contact us at ElectronDevices@cpiedb.com or call us at +1 978-922-6000.



Beverly Microwave Division
150 Sohler Road
Beverly, Massachusetts
USA 01915

tel +1 978-922-6000
email ElectronDevices@cpiedb.com
fax +1 978-922-8914
web www.cpi-edb.com

For more detailed information, please refer to the corresponding CPI EDB technical description if one has been published, or contact CPI EDB. Specifications may change without notice as a result of additional data or product refinement. Please contact CPI EDB before using this information for system design.

©2025 CPI Electron Device Business. Company proprietary; use and reproduction is strictly prohibited without written authorization from CPI EDB.